

Zebra

Two-Stage Rotary Vane Vacuum Pumps RH 0030–0090 B

ENERGOEKONOM
spol. s r.o.



Zebra RH 0030–0090 B

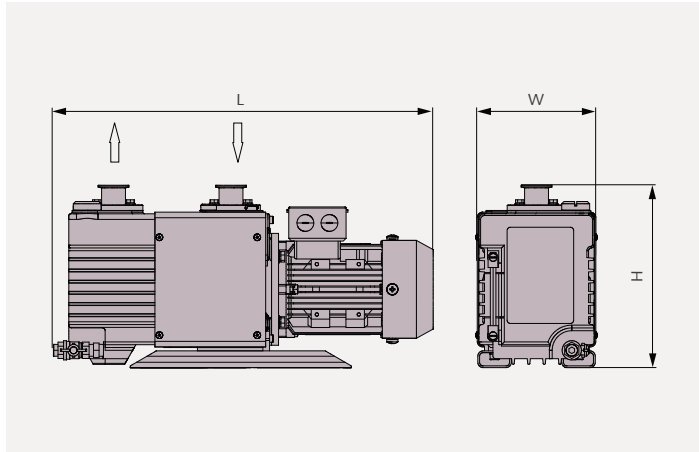

Pumping speed Air at 20 °C. Tolerance: ± 10% — 50 Hz - - - - 60 Hz

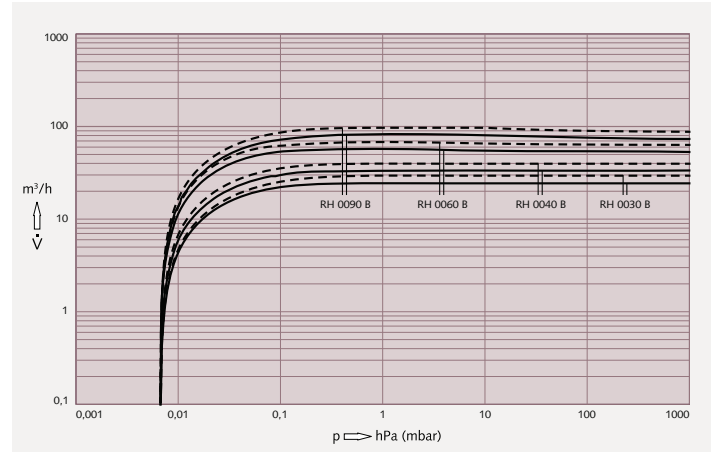

Technical data			RH 0030 B	RH 0040 B	RH 0060 B	RH 0090 B
Pumping speed	50 Hz / 60 Hz	m³/h	24 / 29	33 / 39	55 / 65	80 / 95
Pumping speed	50 Hz / 60 Hz	l/min	400 / 483	550 / 650	917 / 1083	1333 / 1583
Ultimate partial pressure	Gas-ballast valve closed	hPa (mbar)	$6.7 \cdot 10^{-4}$	$6.7 \cdot 10^{-4}$	$6.7 \cdot 10^{-4}$	$6.7 \cdot 10^{-4}$
Ultimate total pressure	Gas-ballast valve closed	hPa (mbar)	$6.7 \cdot 10^{-3}$	$6.7 \cdot 10^{-3}$	$6.7 \cdot 10^{-3}$	$6.7 \cdot 10^{-3}$
Ultimate total pressure	Gas-ballast valve open	hPa (mbar)	$2 \cdot 10^{-2}$	$2 \cdot 10^{-2}$	$2 \cdot 10^{-2}$	$2 \cdot 10^{-2}$
Max. continuous inlet pressure		hPa (mbar)	65	65	65	10
Max. back pressure (gauge)		hPa (mbar)	300	300	300	300
Water vapour capacity	Gas-ballast valve open	g/h	190 / 250	270 / 410	430 / 1100	480 / 600

Motor data three-phase version						
Nominal motor rating		kW	1.5	1.5	2.2	3.7
Energy efficiency class			IE3	IE3	IE3	IE3
Operating voltage	50 Hz 60 Hz	V	200–240 / 380–415 200–240 / 380–460	200–240 / 380–415 200–240 / 380–460	200–240 / 380–415 200–240 / 380–460	200–240 / 380–415 200–240 / 380–460

Physical data						
Ambient temperature		°C	4–40	4–40	4–40	4–40
Oil			VMA 055	VMA 055	VMA 055	VMA 055
Oil capacity		l	2.5	2.5	4	4
Noise level (ISO 2151)	50 Hz / 60 Hz	dB(A)	< 57 / < 61	< 60 / < 64	< 60 / < 64	< 60 / < 66
Weight approx.		kg	58	60	90	113
Dimensions (L x W x H)		mm	671 x 214 x 326	691 x 214 x 326	772 x 264 x 373	831 x 264 x 373
Gas inlet / outlet			ISO-KF 40 / ISO-KF 40	ISO-KF 40 / ISO-KF 40	ISO-KF 40 / ISO-KF 40	ISO-K 63 / ISO-KF 40

Applicable standards						
Marking			cTUVus	cTUVus	cTUVus	cTUVus

Zebra

Two-Stage Rotary Vane Vacuum Pumps RH 0003-0021 B

ENERGOEKONOM
spol. s r.o.



Article Numbers, Genuine Accessories and Spare Parts	RH 0030 B	RH 0040 B	RH 0060 B	RH 0090 B
With three-phase motor				
200-240 / 380-460, 50/60 Hz	1141168799	1141168800	1141168801	1141168802
Inlet accessories¹				
Inlet filter FIL 0080	0530566434			-
Spare polyester filter element for FIL 0080	0532121862			-
Special purpose filter element for FIL 0080	on request			-
Inlet filter FIL 0350	-			0530168812
Spare polyester filter element for FIL 0350	-			0532121864
Special purpose filter element for FIL 0350	-			on request
Outlet accessories²				
Oil mist separator OMS 0040	0960168806			-
Spare filter element for OMS 0040	0532169044			-
Oil mist separator OMS 0090	-		0960168807	
Spare filter element for OMS 0090	-		0532169045	
Oil return line	0946168809			
Other accessories				
Gas-ballast valve	0916168803			
Oil				
VMA 055, 1L	0831169415			
VMA 055, 5L	0831169416			
Maintenance kits				
Minor maintenance kit	0992168950	0992168952	0992168954	0992168956
Major maintenance kit	0993168951	0993168953	0993168955	0993168957

¹ All filters include housing, polyester filter element and mounting hardware
² All oil mist separators include housing, filter element and mounting hardware